

# LV JUICE

## eHome Charging Stations for EV

### LOW COST, ROBUST, USER-FRIENDLY OPERATION

- Designed and manufactured in Spain
- Inbuilt cable holder
- Quality Phoenix Contact vehicle connector (Type 1 & Type 2 available)
- Optional beON sensor ensures eHome charger cannot overload the electrical installation. 20 & 50 amp sensors available ex stock
- Suitable for indoor or outdoor use
- Auxiliary contact allows you to use a timer (or other device) to control when the EV is charging
- 16 amp and 32 amp versions available
  - 16 amp gives around 20-25km of added range per hour\*
  - 32 amp gives around 40-50km of added range per hour\*

\*Actual current limited by size of EV's onboard charger



- SENSOR OPTION
- PLUG N' CHARGE
- DISPLAY
- REMOTE CHARGING



Cat No.	Plug Type	Power (kW)	Amps	Suitable for Home Use
EVC-EHOME-16T1	TYPE 1	3.7	16	✓
EVC-EHOME-16T2	TYPE 2	3.7	16	✓
EVC-EHOME-32T1	TYPE 1	7.4	32	✓
EVC-EHOME-32T2	TYPE 2	7.4	32	✓



### This Month

- IP67 PLUGS & SOCKETS BY FAMATEL PAGE 2
- RAYGEL PLUS JOINT KITS PAGE 4
- PREPARED FOR ANY INCIDENTS? PAGE 6

## FREE TRANSNET BEANIE

WHILE STOCKS LAST



When you spend over \$300 (excl GST) on one invoice this month





**SpeedPRO** plugs and sockets have been designed with all screws oriented in the same direction, eliminating the need to turn them during the cabling process and ensuring a quicker and easier installation.

## Product Specifications

- 400V
- 50/60Hz
- 3P + T + N
- 125A



### FAM14307 Mobile Plug

- With screw terminals
  - Housing material: PA6
  - Contacts: Nickel-plated with pilot contact
- IP67 Watertight



### FAM24307 Mobile Socket

- With screw terminals
- Housing material: PA6
- Contacts: Brass

IP67 Watertight



### FAM24397 Wall Mounted Socket

- With screw terminals
  - Housing material: PA6/ABS
  - Contacts: Brass
  - Top, bottom & rear entry
  - Housing can be rotated by 180°
- IP67 Watertight



**famatel**  
PROFESSIONAL

# IP67 plugs & sockets SpeedPRO



Ergonomically designed socket covers

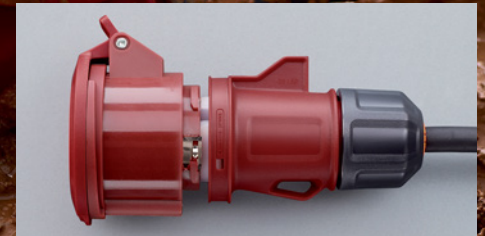

The stainless steel spring safety system ensures precise opening and closing



Famatel's exclusive anti-vibration pressing system aids maintenance and ensures cable flexibility



**Ergonomic, robust, safe, fast and accurate connections.**



## CABLEAWAY PU FLOOR OUTLET BOXES

Our plastic floor outlet boxes are an ideal way to supply power, data and A/V to open floors of a commercial office building or residential home.

POWDER COATED ZINC ANNEALED STEEL BODY

9MM RECESSED PLASTIC LID

20MM AND 25MM KNOCKOUTS PROVIDED FOR EASY CONDUIT ENTRY

DUAL CABLE EXIT FLAPS

FOUR AUTO SWITCHED POWER OUTLETS SUPPLIED

PROVISION FOR EIGHT CAT5 OR CAT6 DATA PORTS



**SHARP PRICE** FBPL4P8D-NZ  
**\$299** +GST

**cable.  
away**

Better Cable Management

## PASSIVE FIRE PROTECTION SYSTEMS BY RYANFIRE

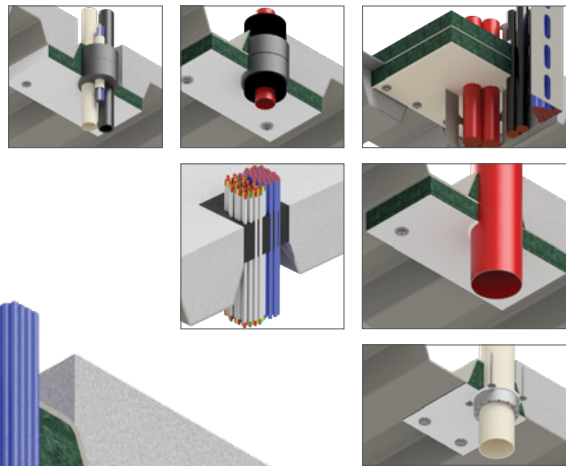

ALL THE SOLUTIONS FOR  
**COMPOSITE  
FLOOR  
SYSTEMS**

CONTACT US FOR  
MORE INFORMATION  
ON PASSIVE FIRE  
PROTECTION SYSTEMS



System Drawing V30.4  
- available on request

# RAYCHEM RAYGEL PLUS JOINT KITS



**Raychem**  
from TE Connectivity



Raychem RayGel Plus Joint Kits offer quick, easy reliable sealed joints for low voltage applications. Enclosures offer a state-of-the-art sealed joint for underground, direct-buried and overhead applications.

## FEATURES

- Housing is made of Halogen free UV resistant Polypropylene
- Insulating material is RayGel PowerGel Sealant
- Some kits include connector blocks or connectors

## WIDE APPLICATION AREA

- Street, garden and pool lighting
- Connection of outdoor equipment
- Frost protection systems
- Cable trays and cable ducts
- With Raychem GelBox 25 joints up to 5x25mm<sup>2</sup> or 4x35mm<sup>2</sup>
- For single-core cables from 10-50mm<sup>2</sup> & multi-core cables from 2x1.5 up to 5x16mm<sup>2</sup>

## SOPHISTICATED ENCLOSURE DESIGN

- Optimised joint design with integrated strain relief and more space for the connection
- Flexible wave-like gel barriers (no tools required)

## UNIVERSAL CONNECTOR BLOCK

- Full range of branching capabilities without cutting of main cables
- Supplementary tool for insertion of sliding nuts
- Unique latchable connector block for even more effective and easy installation

## POWERGEL SEALANT FILLED

- Covers and seals every connection quickly and easily, saving time and effort
- Rated to 90°C continuous temperature
- Environmentally friendly

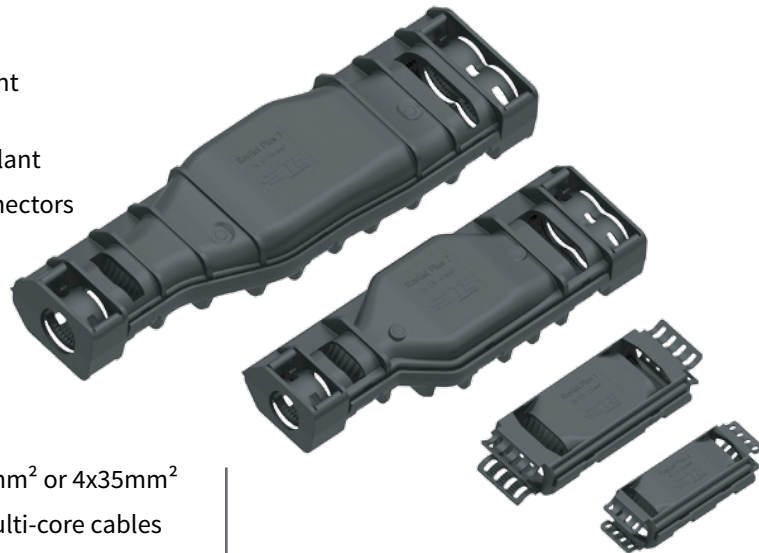

## FIND OUT MORE

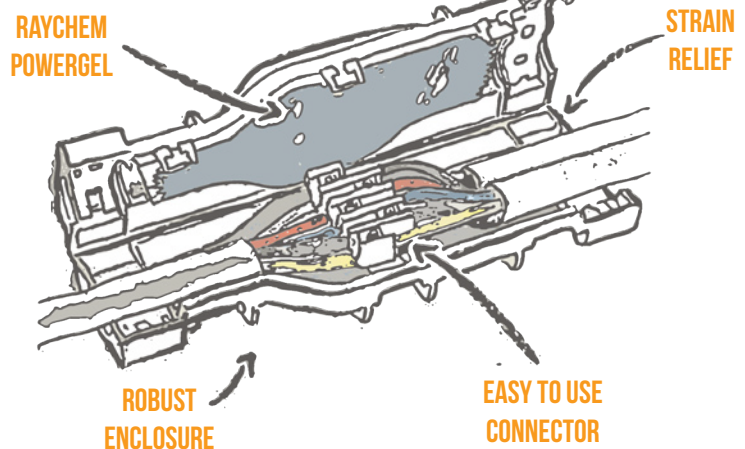

CAT NO.

#RAYGEL-PLUS-0  
#RAYGEL-PLUS-1

#RAYGEL-PLUS-2  
#RAYGEL-PLUS-3



## RDSS - RAYFLATE DUCT SEALING SYSTEM

Raychem's RDSS - Rayflate Duct Sealing System is an inflatable duct sealing system created especially for sealing power cables in ducts. It is also suitable for use with communications cables.



### APPLICATIONS

- For power cables
- For three or more cables, sealing clips are required
- Inflation tool is TDUX-IT-16 for purchase or hire
- Canisters of compressed air or CO<sub>2</sub> are compatible

- Each Rayflate seal covers a large range of cable and duct diameters
- Rayflate seals can be installed when water is still flowing out of the duct – thus saving valuable installation time
- Use not only for new cable installations but also for existing applications
- Rayflate seals can be quickly and easily removed from a duct or pipe by deflation

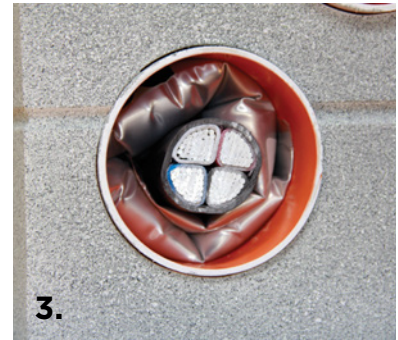

### Installation is fast & easy:

1. Wrap the bag around the cable and ensure it is well seated in the duct before inflating.
2. Connect the inflation tool to the valve on the RDSS bag and inflate to ensure a watertight seal.
3. Finished product.

**Raychem**  
from TE Connectivity



## DUCT SEALING PLUGS

The TE Blank Duct Plug range effectively seal empty conduits. These plugs prevent the flow of water and the costly sedimentation of duct banks and conduit systems while confining problems of dangerous vapors to their source.

Manufactured from high-impact plastic components, combined with durable elastic gaskets, they are corrosion proof and effective for long-term or temporary sealing.

Equipped with a rope tie mechanism that provides the benefit of securing a pull rope to the back compression plate.

### FEATURES

- All plastic construction
- Corrosion proof
- Water and gas tight
- Easy Installation and removal
- Fully removable and reusable



**Raychem**  
from TE Connectivity



All Specials and Products featured in TRANSNET JUICE are available from all good electrical wholesalers.





## BALMORAL WARNING MARKERS

### FEATURES

- Latest technology articulated 3D design
- Premium high-vis reflectors
- Bayonet or Eye Ring fittings available
- Customised flags or marker options available\*
- Universal clamp fits all lines from 2-50mm diameter
- Aerodynamic design, rotates for high impact visibility
- UV stabilised and tough non-conductive plastics
- Anti-creep clamp design
- Installed with standard live line tools

\*Contact us for details



3D VANE



VINYL FLAG

Cat No.	Description
WM-CS-B-1A-RW	3D VANE - BAYONET
WM-CS-E-1A-RW	3D VANE - EYE RING
WM-CS-B-1B-O	VINYL FLAG - BAYONET
WM-CS-E-1B-O	VINYL FLAG - EYE RING



balmoral engineering



## LV RESCUE KIT

# LOW VOLTAGE RESCUE KIT

Designed for use in emergencies around LV electrical systems, this LV rescue kit is perfect for all staff tasked with working on live LV electrical systems, whatever the location.

Supplied in a heavy duty yellow bag for ease of identification, it features clearly labelled essential emergency items with a contents list printed on the inside flap to ensure easy restocking.

### KIT CONTAINS

- Electrosoft 1000V Electrical Gloves Size 10
- First Aid Booklet
- Multi Trauma Dressing
- 'Isolate Here' Sign
- LV Rescue Hook
- Eveready 2D Brilliant Beam Torch VAL2D
- Fire Blanket 1.2M x 1.8m AS/NZS 3504 Approved
- Heavy duty storage bag



### FEATURES

- High quality components
- Kit contents all available individually
- Complies with all relevant standards
- Essential for anyone working on live electricity and live poles
- Suitable for anyone at risk of electric shock including emergency services



**\$125.00**  
+GST

**CAT NO. LVRESCUEKIT**



## MD106 | MD116 | NON-CONTACT VOLTAGE DETECTORS

The MD106 and MD116 are easy-to-operate non-contact voltage testers that are essential tools for both home hobbyists and professionals. They are available with optical, acoustical, and vibrating indicator options, and feature a pocket clip for portability. The MD106 and MD116 can detect live voltage wires in splices, cable plugs, cable drums, sockets, switches and junction boxes. These voltage detectors use a capacitive measuring process – in contrast to inductive measurements, no flow of current is required.

### FEATURES

- Cat IV/1000V overvoltage protection
- IP65 rating
- Lightweight and portable
- Easy to operate

### APPLICATIONS

- General purpose detection
- Low level electrical testing
- Hobby work

### STANDARDS

- IEC60529
- IEC/EN61010
- IEC/EN61140
- IEC/EN61326-1

### KIT CONTENTS

- Non-contact voltage detector MD106 or MD116
- 1.5V AAA batteries x2
- Instruction manual
- Warranty

Function	Technical Data	
	MD106	MD116
DISPLAY	OPTICAL, ACOUSTICAL	OPTICAL, ACOUSTICAL, VIBRATING
MEASUREMENT RANGE	90-1000V AC	12-1000V AC
FREQUENCY RANGE	50 - 60HZ	40-400HZ
TEMPERATURE RANGE	-10°C TO +50°C, <75% RELATIVE HUMIDITY	0°C TO +40°C, <80% RELATIVE HUMIDITY
CURRENT CONSUMPTION	80MA	
DUTY CYCLE	CONTINUOUS	
POWER SUPPLY	2 X 1.5V LR03 BATTERIES (TYPE AAA)	
OVERVOLTAGE CATEGORY	CAT IV/1000V	
DEGREE OF PROTECTION	IP65	
DIMENSIONS	155 X 25 X 23MM	
WEIGHT	APPROX. 56G	APPROX. 58G



## MD106

### MEASURING FUNCTIONS

- Non-contact voltage detection from 90 V AC.
- Optical and acoustical indication in case of power
- 90 V – 1000 V AC measurement range
- Self-test button for verification of operation

## MD116

### MEASURING FUNCTIONS

- Non-contact voltage detection from 12 V AC
- Optical, acoustical, and vibrating indication in case of power
- 12 V – 1000 V AC measurement range
- Automatic self-test



**LED FLASHLIGHT**

**VIBRATING INDICATOR**



# BRIGHT-EYED & BUSHY TAILED

## Panther Tail by Balmoral



**TransNet New Zealand Ltd**

### Auckland

78 Cryers Road  
East Tamaki  
Auckland  
NEW ZEALAND  
Ph 0800 442 182  
Fax 0800 442 183  
PO Box 39 383  
Howick, Auckland

### Wellington

10 Petone Ave  
Petone  
Wellington  
NEW ZEALAND  
Ph 04 576 2530  
Fax 04 576 0040  
PO Box 39 383  
Howick, Auckland

NEW ZEALAND

sales@transnet.co.nz

### TransNet Tonga

#### Ma'ufanga

Small Industries  
Ma'ufanga  
TONGA  
Ph +67 627 939  
Fax +67 627 976  
PO Box 2932  
Nuku'alofa

TONGA

transnet@kalianet.to

Panther Tail is a flexible conductor cover with a unique two tone design (black outside, yellow inside) for ease of visual inspection. Perfect for LV applications, Panther Tails meet the requirements of AS 4202 Class I, Appendix B.

Available by the metre in lengths up to 60m, with a special zip lock style fastening system, Panther Tails are quick and easy to install and can be cut to fit the required area exactly.

### FEATURES

- Excellent weathering, UV, & abrasion resistance
- Low voltage or high voltage applications
- Lightweight and easy to install

### Cat No. TPP15

15mm DIAMETER, BLACK/YELLOW



**balmoral engineering**

TransNet NZ Ltd has made every reasonable effort to ensure the accuracy of this information and it is to the best of our knowledge correct and reliable. Under no circumstances does this constitute an assurance of any particular quality or performance and users should independently evaluate the suitability of products for their desired application. All information in this publication including pricing, drawings, illustrations, images and graphic designs are reflections of our current understanding. TransNet NZ Ltd reserves the right to make any adjustment to this information at any time. Our liability for the products outlined in this publication is set forth in our standard terms and conditions of trade. In case of any potential ambiguities or questions, please contact us for clarification.



NEW ZEALAND OWNED